



VFN series with ratio multiplier RCN series

N50 211N

Riduttori a vite senza fine serie VFN in acciaio inox con precoppia serie RCN

N50 Ratios/Rating

Rapporti/Selezione N50

Ratio	Max output torque ** M_{2R} [Nm]	Tooth module  [mm]	Standard input bore	Ratio code 
i _a				
7	65	2.5	∅19	01
10	71	2.4	∅19	02
14	78	2.6	∅19	03
18	71	2.0	∅19	04
26	76	2.7	∅19	05
30	83	2.5	∅19	12
36	83	2.1	∅14	06
43	78	1.8	∅14	07
50	76	1.5	∅14	13
60	71	1.3	∅14	08
68	66	1.2	∅14	09
80	65	1.0	∅14	10
100	59	0.8	∅14	11

N50 weight
Peso N50

5.30 kg

211N Ratios/Power

Rapporti/potenza 211N

Ratio	Max input power ** P_{1M} [kW]	Output shaft	Ratios code 
i _b			
2.05	0.37	∅14	01
2.35	0.37	∅14	02
2.80	0.37	∅14	03
3.38	0.37	∅14	04
4.70	0.37	∅14	05
6.22	0.37	∅14	06
8.29	0.37	∅14	07
9.83	0.25	∅14	08

211N weight
Peso 211N

2.50 kg



211N Motor flanges

Flange motore 211N

	kit code	g6	A
63B14	KI504047	90	99.5
71B14	KI504045	105	97

How to connect N50+211N

Come collegare N50 + 211N

Worm gearbox		Ratio multiplier	Connection kit	
Standard input bore	Output shaft	211N	With standard input bore	With coupling
N50	∅N	211N		
Ratios from 1/7÷1/30	∅19	∅14	KBR14/19	KC14P
Ratios from 1/36÷1/100	∅14		Reduction bushing is not necessary	

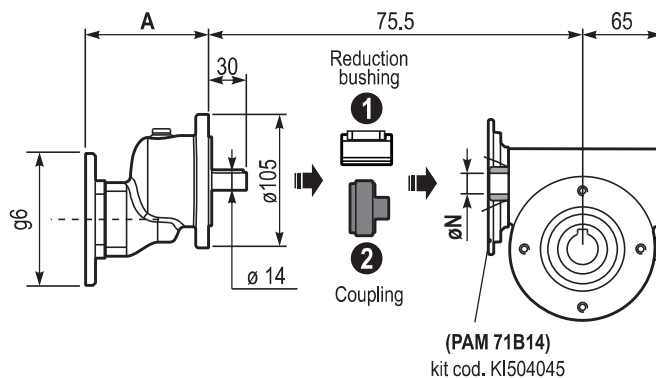

Ratios range: from 1/14 to 1/983

Range rapporti: da 1/14 a 1/983

Lubrication

Lubrificazione

Unit **N50+211N** is supplied with synthetic oil to assure long life lubrication. Food grade oil is available on request. See Table 1 for lubrication and recommended quantity.

Il riduttore tipo **N50+211N** viene fornito con olio sintetico e lubrificazione tipo "long life".

Disponibile a richiesta olio alimentare.

Vedi Tabella 1 per oli e quantità consigliati.

For all details on lubrication and plugs check our website.

Per maggiori dettagli su lubrificazione e tappi olio vedi il nostro sito web.

N50: 0.18 L	SHELL: Omala S4 WE 320	ENI: Telium VSF 320
211N: 0.05 L	SHELL: Omala S4 WE 320	ENI: Telium VSF 320

tab. 1

Calculate total ratio and output speed

Calcola il rapporto totale e la velocità di uscita

Ratios range: from 1/14 to 1/983

Range rapporti: da 1/14 a 1/983

$$i_{TOT} = i_a \cdot i_b$$

Ex.: 1/100 x 1/9.83 = 1/983 (Max ratio)

Output speed (n₂)

Velocità di uscita

$$n_2 = n_1 : i_{TOT}$$

Ex.: 1448 : 983 = 1.47 rpm

i_a : N50 ratio - Rapporto N50

i_b : 211N ratio - Rapporto 211N

**** Make sure input power for 211N and output torque for N50 is as catalogue ratios.**

**** Prestare attenzione a selezionare la potenza in entrata del 211N ed il momento torcente del N50 secondo le tabelle del catalogo.**

n₁ Input speed

Velocità di ingresso